

# KOHLER

MODEL  
K341  
K341A

## ENGINE OWNER'S MANUAL

### CONTENTS

<u>SUBJECT</u>	<u>PAGE</u>	<u>SUBJECT</u>	<u>PAGE</u>
General Specifications	1	Carburetor	6
Location of Service Adjustment Points	2	Governor	7
Precautions	2	Ignition System	8
Pre-start Check List	3	Electric Start	8
Starting-Stopping Procedure	3	Retractable Starter	9
Service Schedule	4	Storage Instructions	10
Lubrication	4	Trouble Shooting Guide	10
Air Cleaner	5	Parts Ordering Instructions	11
Cooling - External Surfaces	5		
Fuel System	6		

## Introduction

This manual covers the Kohler air-cooled, 4-cycle model K341 and K341A gasoline engines with standard equipment. Please take a few moments to review this material then carefully follow all service recommendations to keep your engine in top condition. Some general specifications are listed below. refer to the appropriate service section for specific details. In addition to the routine services covered here, there are other important preventative maintenance steps that should be performed at authorized service centers at periodic intervals--the benefits will not only be noted immediately in improved performance but, most important, in continued satisfactory operation over a long, trouble-free service life.

### GENERAL SPECIFICATIONS

<u>SPECIFICATION</u>	<u>K341</u>	<u>K341A</u>
Bore	3-3/4"	3-3/4"
Stroke	3-1/4"	3-1/4"
Displacement (Cubic Inches)	35.89	35.89
Horsepower (At 3600 RPM)	16	16
Weight (Approximate Lbs.)	123	123
Oil Capacity (U.S. Std. Quart)	2	1
Spark Plug Gap (Std. H-10 Plug)	.025"	.025"
Breaker Point Gap	.020"	.020"

KOHLER CO., KOHLER, WIS. 53044

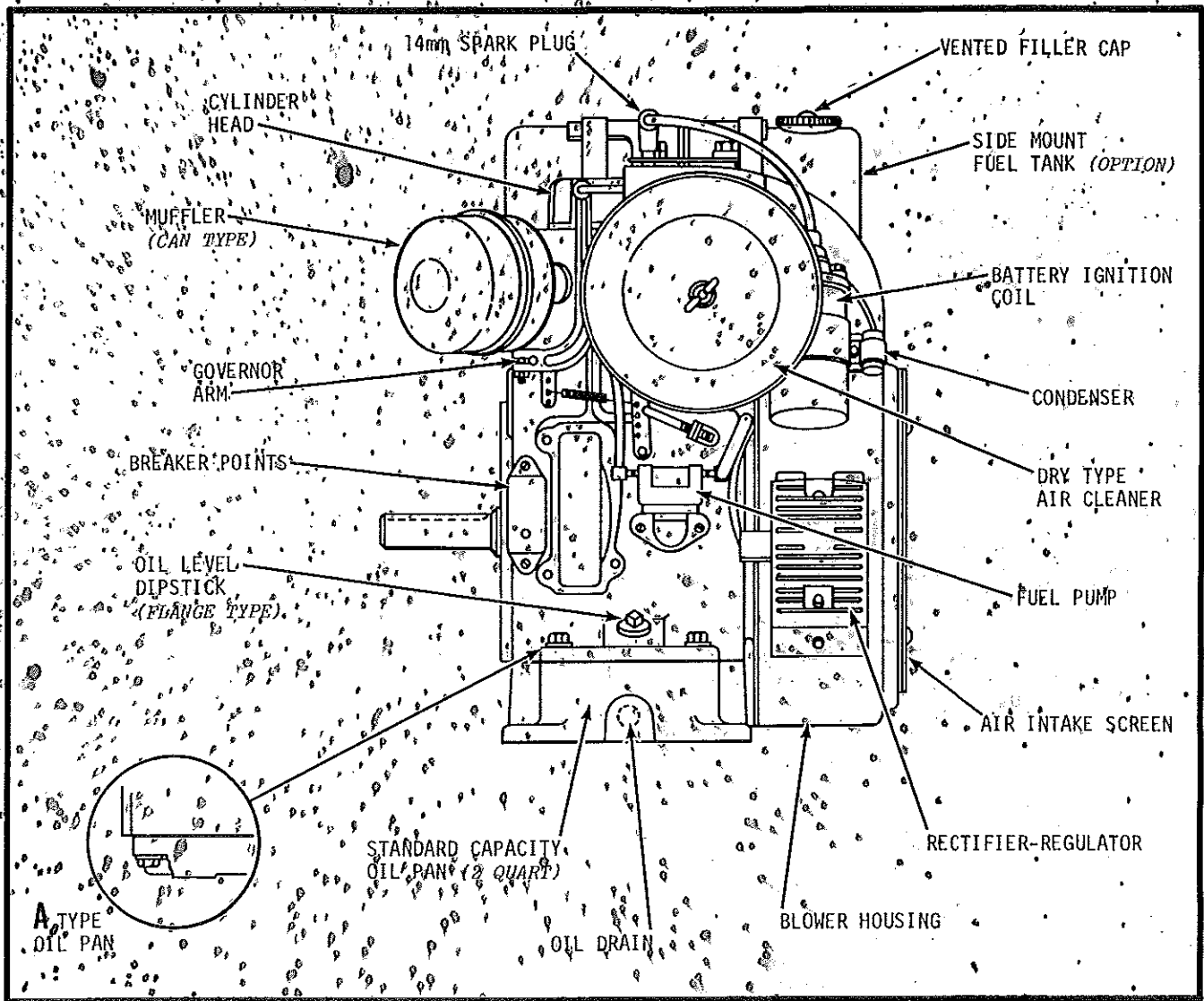

FIGURE -- GENERAL LOCATION OF COMPONENTS ON A TYPICAL SINGLE CYLINDER MODEL

## SAFETY PRECAUTIONS

Power mowers, garden tractors, snowblowers, and other machines powered by air-cooled engines have become so commonplace that we may forget the potential dangers involved in servicing and operation of such equipment. In the interest of safety, some general precautions are presented below as safety reminders. Remember that the best safeguard against accidents is the use of good common sense!

- **WARNING — LETHAL EXHAUST GAS!** An engine discharges carbon monoxide when operating, which causes death if inhaled for even a short period of time — operate only where deadly exhaust gases can be safely dissipated.
- **WARNING — DANGEROUS FUELS!** Use extreme caution when storing, handling and using fuels — they are highly volatile and explosive in vapor state. Store only in approved containers in well ventilated area away from spark or flame producing equipment. Never add fuel to tank while engine is running — stop engine and allow it to cool thoroughly to prevent fuel from igniting on contact with hot parts or ignition spark. Don't store gasoline inside occupied building.
- **WARNING — MOVING HOT PARTS!** Imprudent operation of power equipment creates hazards to life and limb — never operate with safety guards removed, keep hands, feet, clothing away from moving and hot parts. Remember that an engine gets hot while running, and exhaust system components get extremely hot. Know how to make emergency stops — don't allow inexperienced persons to operate your equipment. Always disconnect or remove spark plug to prevent unintentional starting while working on equipment. Never tamper with governor setting to gain more power — the governor establishes safe operating limits. Overspeed not only shortens engine life but can be extremely hazardous. Keep people safely away from the operating area and be especially watchful for children. Stop the engine whenever you leave the equipment — don't allow it to idle unattended.
- **WARNING — GENERAL PRECAUTIONS!** Handle starting batteries carefully — they are filled with acid which can eat thru clothing, burn skin, and cause blindness. Keep in mind that a battery gives off highly flammable hydrogen gas while being charged — charge only in well ventilated area. While electrical energy produced in an engine ignition system may not be strong enough to cause injury, reaction to shock produced could cause you to pull away and into contact with hot or moving parts — keep away from ignition system while operating. Never operate without adequate muffler or with faulty exhaust system — exposure to excessive noise is not only tiring but can lead to impairment of hearing.





# OPERATING INSTRUCTIONS

## PRE-START CHECK LIST

- **OIL LEVEL:** Add oil as needed to keep level in safe range between L and F marks on the dipstick. See Page 4 for oil recommendations.
- **FUEL:** Fill fuel tank with clean, fresh REGULAR grade of gasoline. Use leaded or non-leaded type but make sure octane rating is at least 85. Don't mix oil with gasoline. If engine has a fuel filter, clean sediment bowl if needed.
- **COOLING:** Check air intake screens and cooling fins--keep them clean and unrestricted.
- **AIR CLEANER:** Make sure cleaner and intake parts are tight and properly installed to prevent unfiltered air from entering the engine.
- **BATTERY (ELECTRIC START):** Keep battery surface clean to prevent self-discharge. Check electrolyte level. Connections must be tight and negative (-) terminal must be the ground terminal.

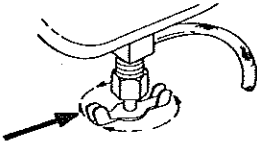
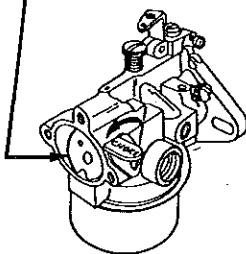
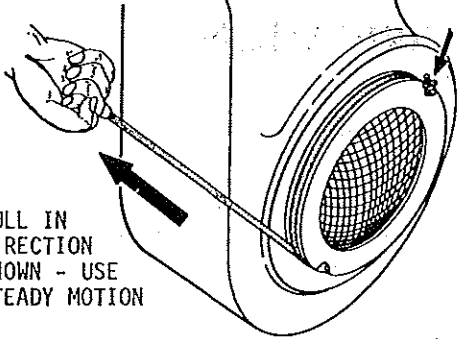
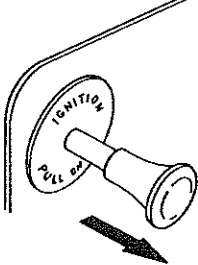
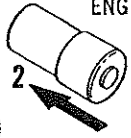
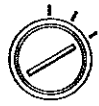
## STARTING PROCEDURE

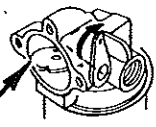
TURN FUEL ON	CLOSE CHOKE	MANUAL START MODELS
<p>TURN FUEL VALVE TO ON POSITION</p> 	<p>MOVE CHOKE TO CLOSED POSITION</p> 	<p>PULL IN DIRECTION SHOWN - USE STEADY MOTION</p> 
ELECTRIC START		OPEN CHOKE
<p>1. PULL IGNITION KNOB OUT*</p>  <p>2. DEPRESS AND HOLD START BUTTON UNTIL ENGINE STARTS</p> 	<p>KEYSTART - MOVE KEY TO START POSITION, *RELEASE WHEN ENGINE STARTS (SWITCH AUTOMATICALLY RETURNS TO RUN)</p>  <p>*OR MOVE TOGGLE SWITCH TO "ON" POSITION</p>  	<p>GRADUALLY RETURN CHOKE TO OPEN POSITION AFTER ENGINE STARTS</p> 

## STOPPING PROCEDURE

**DISENGAGE DRIVE ● TURN IGNITION OFF ● TURN FUEL OFF**

**EMERGENCY STOP:** IF ENGINE CONTINUES RUNNING WHEN IGNITION IS TURNED OFF, CLOSE CHOKE AND OPEN THROTTLE TO STALL ENGINE--DON'T PULL IGNITION LEADS TO STOP.

# SERVICE - ADJUSTMENT

## SERVICE SCHEDULE

PERFORM SERVICE AT INTERVALS INDICATED (X)	EACH DAY	EVERY 25 HOURS	EVERY 50 HOURS	EVERY 100 HOURS	EVERY 500 HOURS
CHECK OIL LEVEL (maintain in safe operating range) ---	X				
CLEAN AIR INTAKE SCREEN (plus other external surfaces) -	X				
REPLENISH FUEL SUPPLY (Use clean, fresh fuel) -----	X				
CHANGE OIL (Use API Service SC of proper weight) -----		X			
CHECK AIR CLEANER ELEMENT (dry type only) -----			X		
SERVICE SPARK PLUG (gap .025" for gasoline) -----				X	
SERVICE BREAKER POINTS (gap .020") -----					X

**NOTE:** Intervals stated are for good, clean operating conditions--perform services more frequently if dusty or dirty conditions prevail.

## LUBRICATION

**OIL LEVEL:** With the splash system, the oil level must be maintained on the "Safe" operating range at all times--this is between the F (full) and L (low) mark on the dipstick. Check the level daily and add oil as needed. DO NOT OVERFILL--oil level must not exceed F mark.

On engines with the threaded type plug-dipstick, turn the plug all the way out of crankcase, wipe oil off dipstick then re-insert--do not turn plug in to check oil--shoulder plug on top of hole then remove to observe level. After checking oil, turn plug all the way into crankcase. With the extended oil fill tube and dipstick, push dipstick all the way down on tube then take reading. Engine must be level for accurate reading.

MODEL	OIL CAPACITY(U.S. STANDARD MEASURE)
K341	2 QUARTS
K341A	1 QUART

**OIL TYPE:** Oils meeting the requirements of the American Petroleum Institute's (API) Service classification SC\* are suitable for use in Kohler Air Cooled Engines. Service SC oils are detergent type oils. Oil viscosity (weight) is selected according to the anticipated ambient temperatures. The temperature-viscosity recommendations are:

AIR TEMPERATURE	OIL VISCOSITY
Above 30° F.	SAE 30
30° F. to 0° F.	SAE 10 W - 30
Below 0° F.	SAE 5 W - 20

\*API Service CC (MIL-2104B) and SD class oils may also be used.

**OIL CHANGE:** On new or rebuilt engines, the oil should be changed after the first five hours of operation--thereafter each 25 hours of operation under normal conditions. If extremely dusty or dirty conditions prevail, change oil more frequently. If possible, run engine just prior to changing oil--the oil will flow more freely and carry away a greater amount of contamination when it is hot.

## AIR CLEANERS

Dirt induced through improperly installed, poorly serviced or inadequate air cleaner elements wears out more engines than does long hours of operation. Even a small amount of dirt will wear out a set of piston rings in a few hours. Also, a clogged element causes a richer fuel mixture which may lead to formation of harmful sludge deposits. Always cover carburetor or air horn when air cleaner is removed. Service dry type air cleaners as follows:

**SERVICE - REPLACEMENT:** Dry type elements should be replaced after 100 to 200 hours if engine is operated under good clean air conditions--service and replace element more frequently under extremely dusty or dirty conditions. Dry elements should be cleaned after about each 50 hours of operation--remove element and tap lightly on a flat surface to remove loose surface dirt. Replace element if dirt does not drop off easily. Do not wash dry elements in any liquid or attempt to blow dirt off with air hose as this will puncture filter element. When replacing element, use only genuine Kohler elements. Carefully handle new element--do not use if gasket surfaces bent or twisted. Check the following when installing new or serviced element:

1. Back plate must be securely tightened to carburetor. Replace back plate if bent or cracked.
2. Gasket surfaces of element must be flat against back plate and cover to seal effectively.
3. Wing nut must be finger tight--don't overtighten.

**PRECLEANERS:** Precleaners are available for use with dry type air cleaners. The precleaner traps much of the dirt, preventing it from entering the dry element thereby extending its life. No modification is needed--the precleaner slips right over the dry element. Servicing of the precleaner is accomplished by washing it in soap and water then, after rinsing and squeezing out excess water, allowing it to air dry (whenever possible), then reinstall it over element. DO NOT oil this type precleaner.

## COOLING & EXTERNAL SURFACES

Air is drawn into the cooling shroud by fins provided on the flywheel. The rotating air screen and the cooling fins on the block and cylinder head must be kept clean and unobstructed at all times. Never operate engine with blower housing or cooling shrouds removed. These direct air flow past cooling fins. Removal results in improper air circulation and overheating. External surfaces must be in clean condition free of any oil and dirt accumulation.

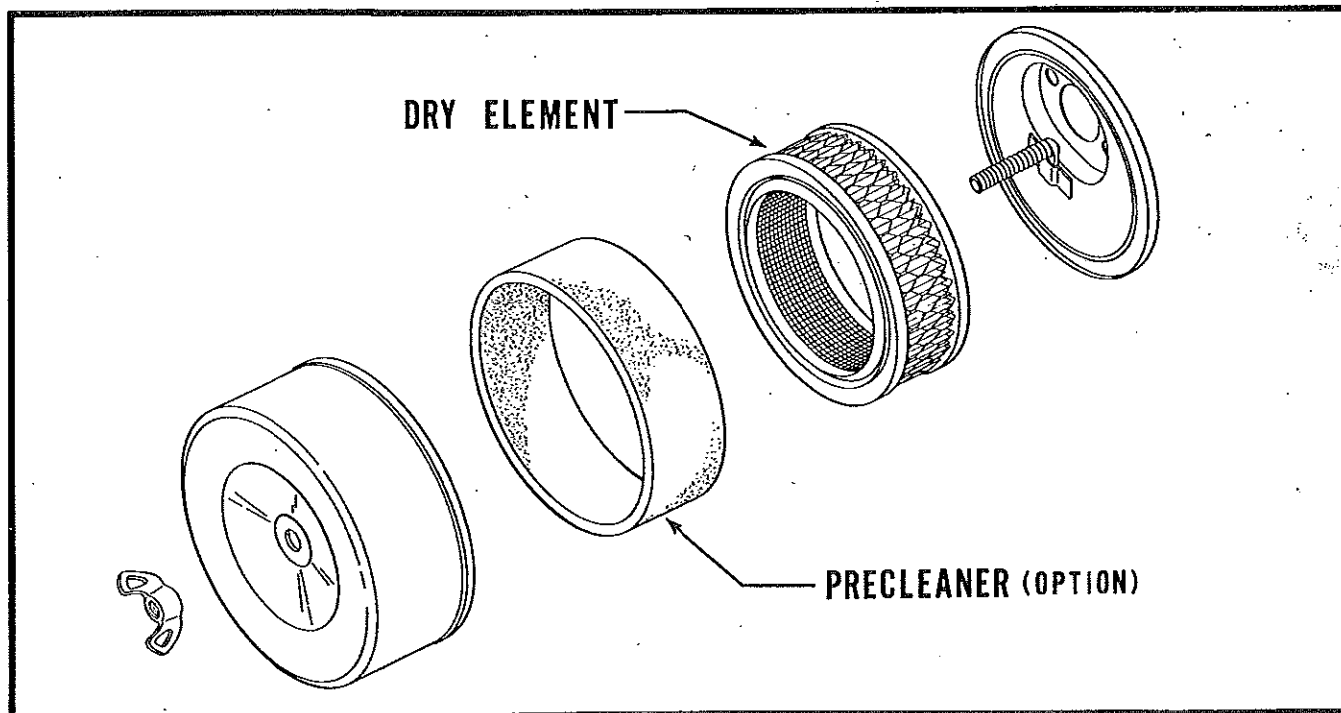

FIGURE 2 -- DRY TYPE AIR CLEANER WITH SERVICEABLE PRE-CLEANER OPTION

## FUEL, FUEL SYSTEMS

With the gasoline fuel system, use clean fresh REGULAR grade of leaded or non-leaded gasoline with octane rating of at least 85. The non-leaded (or low lead) fuels offer the advantage of reducing the amount of deposits which build up in the combustion chamber. Do not add oil to the gasoline on these 4-cycle engines. Use name brand gasoline purchased from popular stations to prevent use of stale gasoline or fuel not adjusted to seasonal changes. Gasoline becomes "stale" after about 6 months and tends to form gum deposits which clog the fuel system especially small passages in the carburetor. When placing an engine in storage, completely drain fuel lines, tanks and carburetor bowl or use a fuel stabilizer which prevents formation of gum in the gasoline. On gravity feed systems, turn the fuel valve off whenever the engine is to be out of service for any length of time--this will prevent seepage of gasoline into the engine. Keep the vent hole in the gas filler cap open--if it becomes plugged, flow of fuel will be impaired.

## CARBURETOR

Lack of power accompanied by black, sooty exhaust smoke usually indicates that fuel mixture is too rich. An "overrich" mixture may also be caused by a clogged air cleaner--check this before readjusting carburetor. Main Fuel may be set too lean if engine "skips" or backfires at high speed. The following procedure applies to the standard gasoline carburetor--refer to the Popular Option section for adjustment of gas fuel system if your engine is so equipped.

**MAIN FUEL ADJUSTMENT:** For preliminary setting, turn MAIN FUEL screw in clockwise direction until it bottoms lightly (do not force) then back out 2 turns. With engine thoroughly warmed up and running at full throttle and full load (when possible), turn MAIN FUEL screw in until engine slows down (lean setting) then turn screw back out until engine regains speed and then starts to slow down again (overrich setting)--turn screw back in until it is positioned halfway between lean and overrich settings--when properly adjusted, engine will accelerate smoothly and operate with steady governor action.

**IDLE ADJUSTMENT:** Rough idle is usually caused by the idle speed being set too low. Turn IDLE SPEED screw in (clockwise direction) to increase speed.\* If engine still idles poorly after speed is increased, stop engine and turn IDLE FUEL screw all the way in (clockwise) until it bottoms lightly (do not force screw) then back out 1-1/4 turns. Restart engine and check idle--turn needle in or out (1/4 turn at a time) until smoothest idle is achieved.

*\*Idle speed normally set at 1450-1500 RPM when engine is in equipment.*

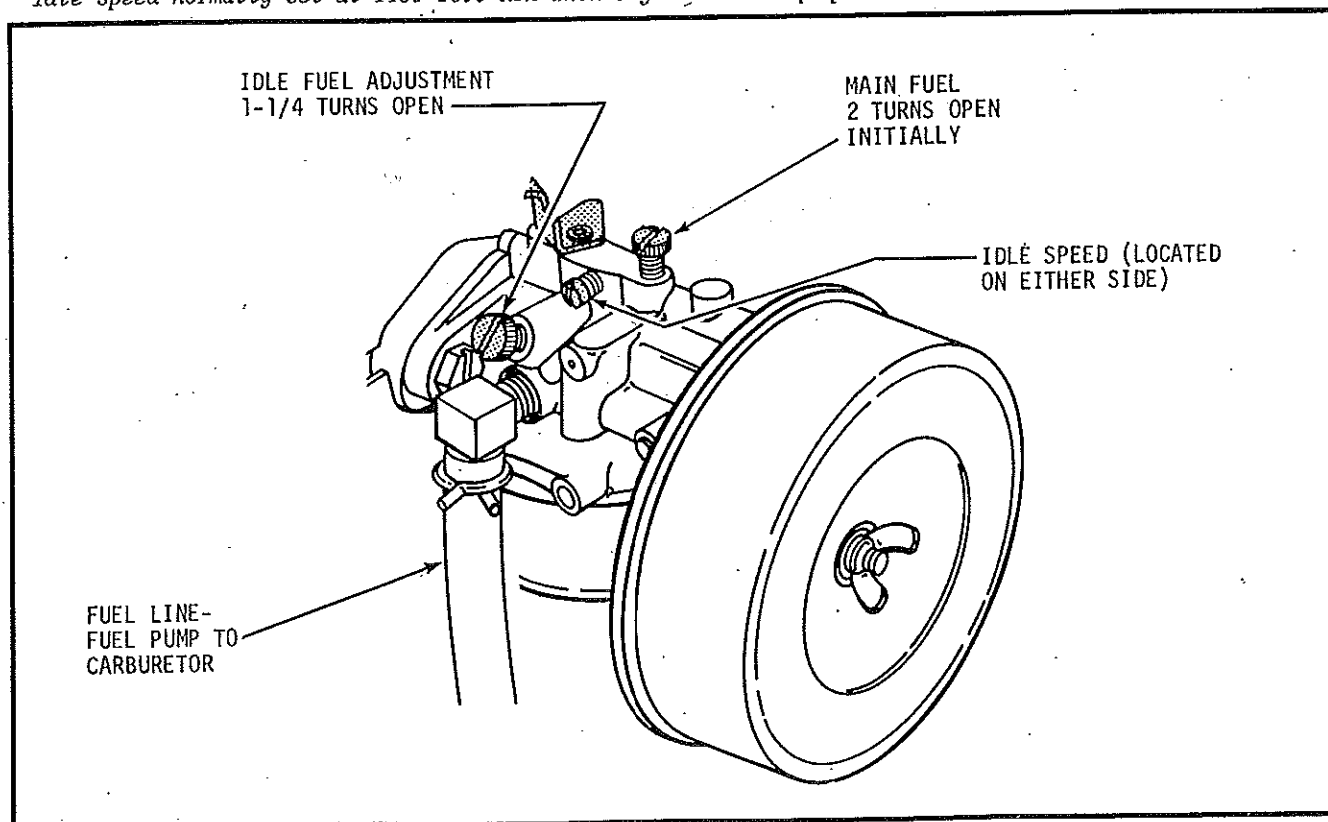

FIGURE 3 -- GASOLINE CARBURETOR - TYPICAL LOCATION OF ADJUSTMENTS

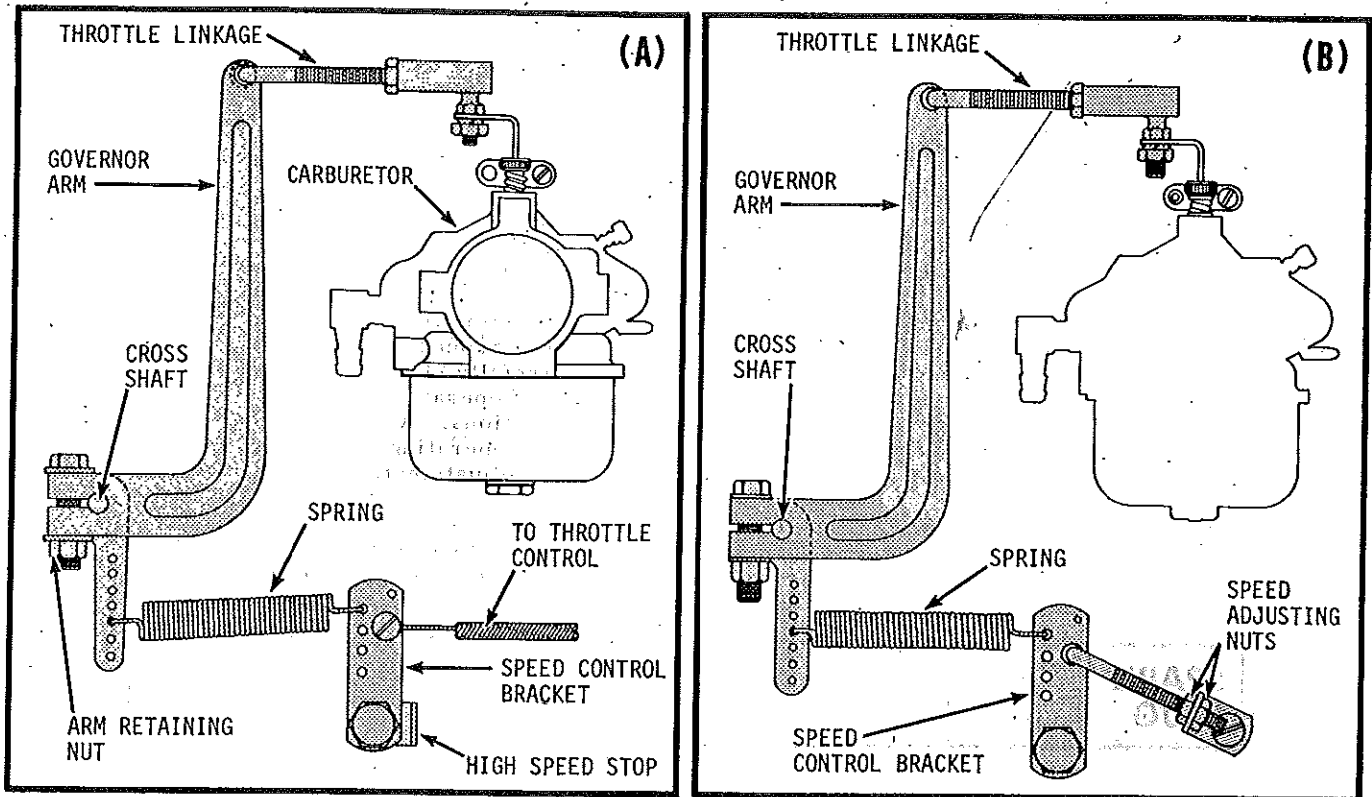

FIGURE 4 -- GOVERNOR ADJUSTMENTS: (A) VARIABLE SPEED TYPE (B) CONSTANT SPEED TYPE

## GOVERNOR

The governor functions to maintain engine speed under changing load conditions and also acts as a speed limiting device. Governors are set in the factory and further adjustment should not be required unless linkage works loose or becomes disconnected. Readjustment should be made if engine surges with changing load or if speed drops considerably when a normal load is applied. Two types of governor arrangements are shown above--adjust per instructions for the type used on your engine.

**INITIAL ADJUSTMENT:** With engine stopped, loosen (do not remove) hex nut securing governor arm to governor cross shaft. Grasp end of cross shaft with pliers and turn shaft as far as possible in counterclockwise direction--tab on shaft will stop internally against governor gear mechanism. Hold shaft in this position, pull governor arm all the way away from carburetor then retighten governor arm nut to complete initial adjustment.

**THROTTLE WIRE INSTALLATION:** Note hole position of throttle wire on old engine and install in same holes on Service Engine. Install wire as follows: Move throttle control handle to full throttle position (F or Open mark) then bend end of wire into a small hook and insert open end into handle lever hole located inside control cover.

**SPEED ADJUSTMENT:** Maximum allowable speed for most engines is 3600 RPM. This speed must not be exceeded. If overspeed condition is suspected, check RPM's with hand tachometer and readjust as follows:

1. With constant speed arrangement loosen speed adjusting nut to decrease speed or tighten to increase speed.
2. With variable speed type arrangement as shown, loosen capscrew and move high speed stop bracket until desired maximum speed is attained--retighten capscrew to lock bracket in new position.

**SENSITIVITY ADJUSTMENT:** If speed drops considerably when a normal load is applied, governor should be set for greater sensitivity. If set too sensitive, speed surging will occur with changing load. Governor sensitivity is adjusted by repositioning governor spring in holes provided on arm and speed control brackets. Increase tension in spring (and sensitivity) by moving spring hooks into holes spaced further apart--conversely, decrease sensitivity by reducing tension on spring.



# IGNITION SYSTEM SERVICE

Your engine may have flywheel-magneto, battery or breakerless type ignition. Battery and breakerless systems can be identified by shape of ignition coil which is mounted on the outside of the engine--refer to the illustration below. With flywheel-magneto ignition, the coil is not visible since it is assembled to the bearing plate inside the flywheel.

Engine skip, hard starting, poor performance is most often due to incorrect plug gap or breaker point gap. These symptoms may also appear when the plug is fouled or in poor condition or when the points are burned or pitted. The following service recommendations apply to all systems except, of course, the breakerless system which does not have breaker point or condenser as discussed.

**SPARK PLUG:** Check condition and reset gap at about 100-hour intervals. The gap gradually widens as the electrodes wear under normal conditions. Always clean area around plug before removing to prevent dirt from falling into the head as the plug is removed. Carefully check condition of electrodes after removing the plug as this usually offers a good indication of operating conditions. If the plug has a light coating of gray or tan, this usually indicates normal conditions. A dead white blistered coating may indicate overheating while black coating usually comes from operating with overrich fuel mixture which can be caused by clogged air cleaner or carburetor out of adjustment.

Do not sandblast, wire brush, scrape or otherwise attempt to service a plug that is badly fouled or in poor condition--best results are obtained with a new plug. Before installing plug, set gap at .025" for gasoline operation, then tighten the spark plug with a torque wrench to 22 foot pounds.

SPARK PLUG	SIZE	STANDARD GASOLINE	SPARK GAP	TORQUE
	14MM	H10 OR EQUIVALENT	.025"	22 FT. LBS.

**BREAKER POINTS:** Every 500 hours breaker points should be inspected and serviced. If oxidized, dirty or oily, lean with coarse cloth--do not use emery cloth or sandpaper. Slightly pitted points can be dressed with point file--replace badly pitted or burned points. The gap must be adjusted whenever points are serviced or replaced since this setting establishes ignition timing. To adjust, turn crankshaft until points are wide open or at maximum separation then check with feeler gauge. If gap is not .020", loosen adjusting screw and shift movable plate until correct gap of .020" is obtained. After retightening screw, check to make sure gap is still properly set as this sometimes alters the setting slightly.

## BREAKER POINT GAP - - .020"

**CONDENSER:** If the condenser shorts out, the coil will be unable to function at all. If it opens and decreases in capacitance, the output voltage will be greatly reduced and the ignition points will burn excessively. If condenser has too little capacitance, metal will transfer from the stationary contact to

the movable contact. If capacitance is too great, the metal will build up on the stationary contact. Make sure the condenser is the correct one for your engine.

**IGNITION COIL:** These coils do not require servicing on a regular basis; however, they should be kept in clean condition and the terminals and connections must be tight to provide good electrical contact. The rubber nipple on the high tension terminal must be in good condition to prevent leakage of current across exposed surfaces.

## ELECTRIC START MODELS

**STARTING-MOTOR SYSTEM:** These starters are pre-lubricated during assembly and do not require further lubrication or service under normal conditions. Starter service should be performed only at authorized repair shops.

**Precautions:** In the event of a "false start"; that is, if the engine gets up sufficient speed to disengage the starter but then fails to continue running, the engine must be allowed to come to a complete halt before a restart attempt is made. If the flywheel is still rotating when the starter is engaged, the pinion and ring gear may clash and damage the teeth. Continuous cranking time should be limited to 60 seconds. If an engine fails to start after this length of time, it may be out of fuel, flooded, have poor ignition or there is some other condition preventing it from starting. Make sure the special shouldered capscrews (and lock washers) are used when installing starter. These special capscrews properly align the pinion



to the ring gear on the engine--use of ordinary capscrews will allow the starter to shift and result in clashing of the gears. Keep these mounting capscrews tight.

**Rectifier-Regulator:** The rectifier-regulator unit used with the starting motor system is a solid-state device and is non-serviceable. This unit will be damaged if the engine is operated for any length of time without the battery in the system--also, to protect this unit, disconnect the leads before doing any welding on equipment in common ground with it.

**BATTERY:** Use 12 volt negative battery (- terminal ground) with amp hour rating of at least 32 for best results. When battery is in good condition, each cell contributes approximately 1.95 to 2.08 volts. If the charge is low and less than 0.05 volt difference is noted between the cells having the highest and lowest readings, the battery should be recharged. If the difference is more than .05 volts, this could indicate a cracked plate or other damage which could call for replacement of the battery.

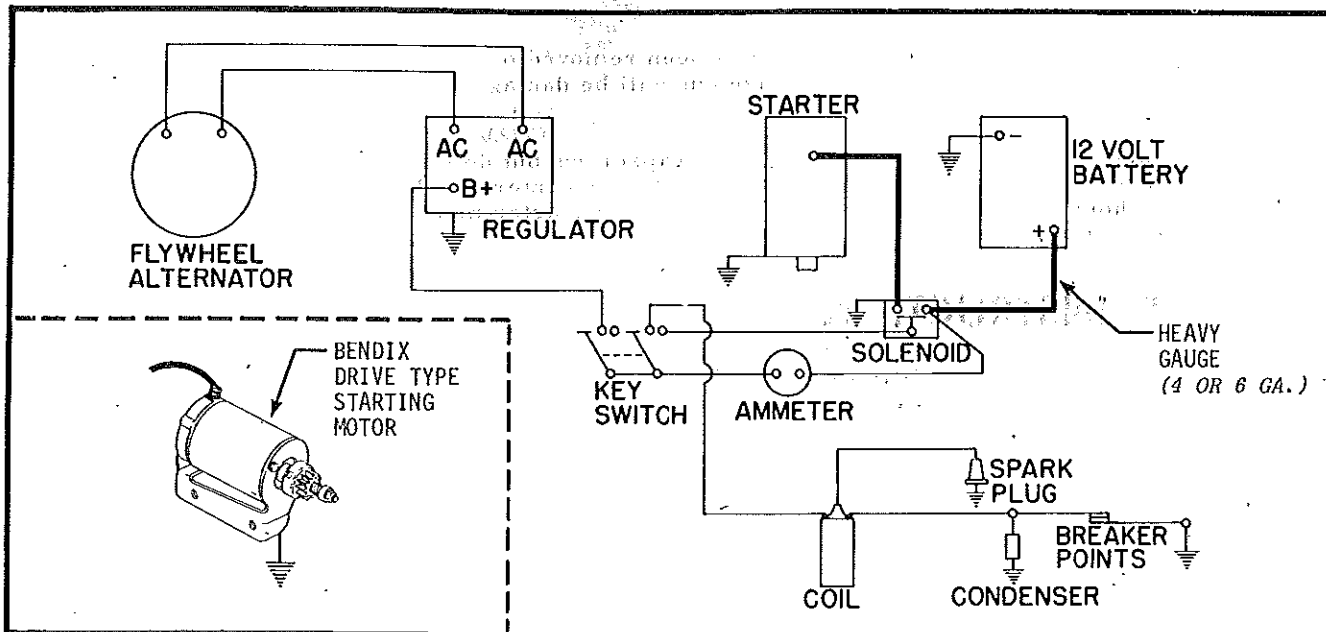

FIGURE 5 -- WIRING DIAGRAM FOR 15 AMP ALTERNATOR - BATTERY IGNITION SYSTEM

As a battery discharges, sulfuric acid is chemically withdrawn from the electrolyte and lead sulfate deposits continue to build up on the plates. This results in a diminishing specific gravity of the electrolyte. If the specific gravity drops below 1.240, the battery should be recharged. In fully charged condition, the specific gravity will be in the 1.260 - 1.280 range. (Note: In tropical areas where the temperature stays well above freezing, an electrolyte with lower specific gravity may be used--full charge specific gravity of this is 1.225.)

A regulator may be blamed for an undercharged or repeatedly discharged battery when the fault is actually self-discharge caused by a build-up of corrosive acid across the top of the battery. Even a light coating of this grayish-white substance can complete a circuit to drain and exhaust the energy in the battery--this can be especially bad when moisture is present. Service as indicated in the following.

To maintain a battery in top condition, check and perform the following services at frequent intervals:

1. Regularly check level of electrolyte--add water as necessary to maintain level above plates --do not overfill as this can cause poor performance or early failure due to loss of electrolyte.
2. Keep terminals and top of battery clean. Wash with baking soda and rinse with clear water. Do not allow soda solution to enter cells as this will destroy the electrolyte.

# RETRACTABLE STARTER

While retractable starters do not require servicing, they should be checked occasionally to make sure they are secure and also that the rope is in good condition. If the rope is frayed, replace it immediately. It's a relatively simple job to replace the rope before it breaks, but if it does break, the pulley is free to unwind violently which can result in a broken spring or other damage calling for rebuilding of the starter. After removing starter from engine, replace the rope as follows--make sure starter is realigned with the drive cup when it is reinstalled on the engine.

**ROPE REPLACEMENT:** If the rope has not broken, simply pull the rope to its full extended position, secure the pulley in this position (block it to prevent it from rewinding), cut the knot off and remove the old rope. Install the handle on a rope, slip the other end in thru the bushing in housing and the hole in the pulley, install the rope retainer washer, then tie a knot in rope--carefully burn end slightly to fuse it, making it a permanent knot. Slowly release the pulley--brake it so that the rope winds slowly around the pulley until it is fully retracted. Realign starter to drive cup per the instructions below. If rope was broken, it will be necessary to return the starter unit to an authorized service center for repair--don't attempt to disassemble these starters as the rewind spring can unwind violently if improperly handled.

**ALIGNMENT:** Whenever retractable starter has been removed or has worked loose on engine, it must be realigned. If this is not done, teeth in drive cup will be damaged. Use the following procedure to align starter.

1. Attach starter to engine with retaining capscrews but do not tighten capscrews all the way.
2. Pull starter handle out about 8" so that starter centers as dogs engage in the drive cup then hold rope in this position while tightening starter mounting capscrews to complete installation.

# STORAGE INSTRUCTIONS

Use the following procedure to preserve engine before placing in storage. Drain oil from crankcase (while hot) then flush with clean light oil. Refill crankcase after flushing. Drain fuel from tank, sediment bowl and carburetor. Clean exterior of engine then spread light film of oil over surfaces subject to corrosion (unpainted metal surfaces). Pour tablespoon of oil into spark plug hole, turn engine over several times by hand then reinstall plug. Cover engine and store in dry place.

# TROUBLE SHOOTING

If trouble occurs, don't overlook causes that seem too obvious to be considered such as an empty fuel tank--check for the simplest causes first. To operate, an engine must have fuel, a good ignition spark and, of course, good compression--keep this in mind when trying to pinpoint the cause of a problem. The following is offered as a guide for correcting some of the problems that are possible with a 4 stroke cycle engine.

## TROUBLE SHOOTING GUIDE

<p><b>HARD STARTING OR LOSS OF POWER</b></p> <ol style="list-style-type: none"> <li>a. Faulty ignition.               <ol style="list-style-type: none"> <li>1. Leads grounded or loose.</li> <li>2. Breaker points faulty or improperly gapped.</li> <li>3. Spark plug faulty or improperly gapped.</li> <li>4. Coil or condenser defective.</li> </ol> </li> <li>b. Faulty carburetion.               <ol style="list-style-type: none"> <li>1. Fuel line clogged (dirt-gum)</li> <li>2. Fuel pump faulty.</li> <li>3. Carburetor dirty or improperly adjusted.</li> </ol> </li> <li>c. Poor compression.               <ol style="list-style-type: none"> <li>1. Head loose or gasket leaking.</li> <li>2. Valves sticking or leaking.</li> <li>3. Piston rings worn.</li> </ol> </li> </ol>	<p><b>OPERATING ERRATICALLY</b></p> <ol style="list-style-type: none"> <li>a. Clogged fuel line.</li> <li>b. Water in fuel.</li> <li>c. Vent in gas cap plugged.</li> <li>d. Faulty fuel pump.</li> <li>e. Gasket leaking (carb.-manifold)</li> <li>f. Governor improperly set.</li> <li>g. Carburetor improperly adjusted.</li> </ol> <p><b>KNOCKING</b></p> <ol style="list-style-type: none"> <li>a. Fuel octane too low.</li> <li>b. Ignition timing wrong</li> <li>c. Carbon build-up in combustion chamber.</li> <li>d. Engine overheated.</li> </ol> <p><b>OCCASIONAL "SKIP" AT HIGH SPEED</b></p> <ol style="list-style-type: none"> <li>a. Spark plug fouled, faulty or gap too wide.</li> <li>b. Ignition timing wrong</li> <li>c. Carburetor improperly adjusted.</li> </ol>	<p><b>OVERHEATING</b></p> <ol style="list-style-type: none"> <li>a. Air intake screen or fins clogged.</li> <li>b. Oil level too high (or low).</li> <li>c. Fuel mixture too lean</li> <li>d. Ignition timing wrong</li> <li>e. Engine overloaded.</li> <li>f. Tappet clearance too close.</li> </ol> <p><b>IDLES POORLY</b></p> <ol style="list-style-type: none"> <li>a. Idle Speed too low.</li> <li>b. Idle Fuel improperly adjusted.</li> <li>c. Gasket leaking (carb.-manifold)</li> <li>d. Spark plug gap too close.</li> </ol> <p><b>BACKFIRING</b></p> <ol style="list-style-type: none"> <li>a. Carburetor set too lean (Main Fuel).</li> <li>b. Breaker points improperly gapped (timing).</li> <li>c. Valve sticking.</li> </ol>
---	---	--

# PARTS ORDERING INSTRUCTIONS

In any correspondence regarding your engine or when ordering replacement parts, please report the MODEL, SERIAL, and SPECIFICATION numbers as found on the nameplate of your engine. The nameplate is located on the blower housing. This information will enable the Kohler Engine Dealer to supply the right part for your particular engine version. Part numbers are not listed in this manual due to variation in engines in this series--use the exploded view below to identify parts. Do not attempt to replace major items or items that call for special adjustment procedures--have this work done only by qualified engine specialist. Check the yellow pages of your telephone directory for the nearest Kohler Dealer.

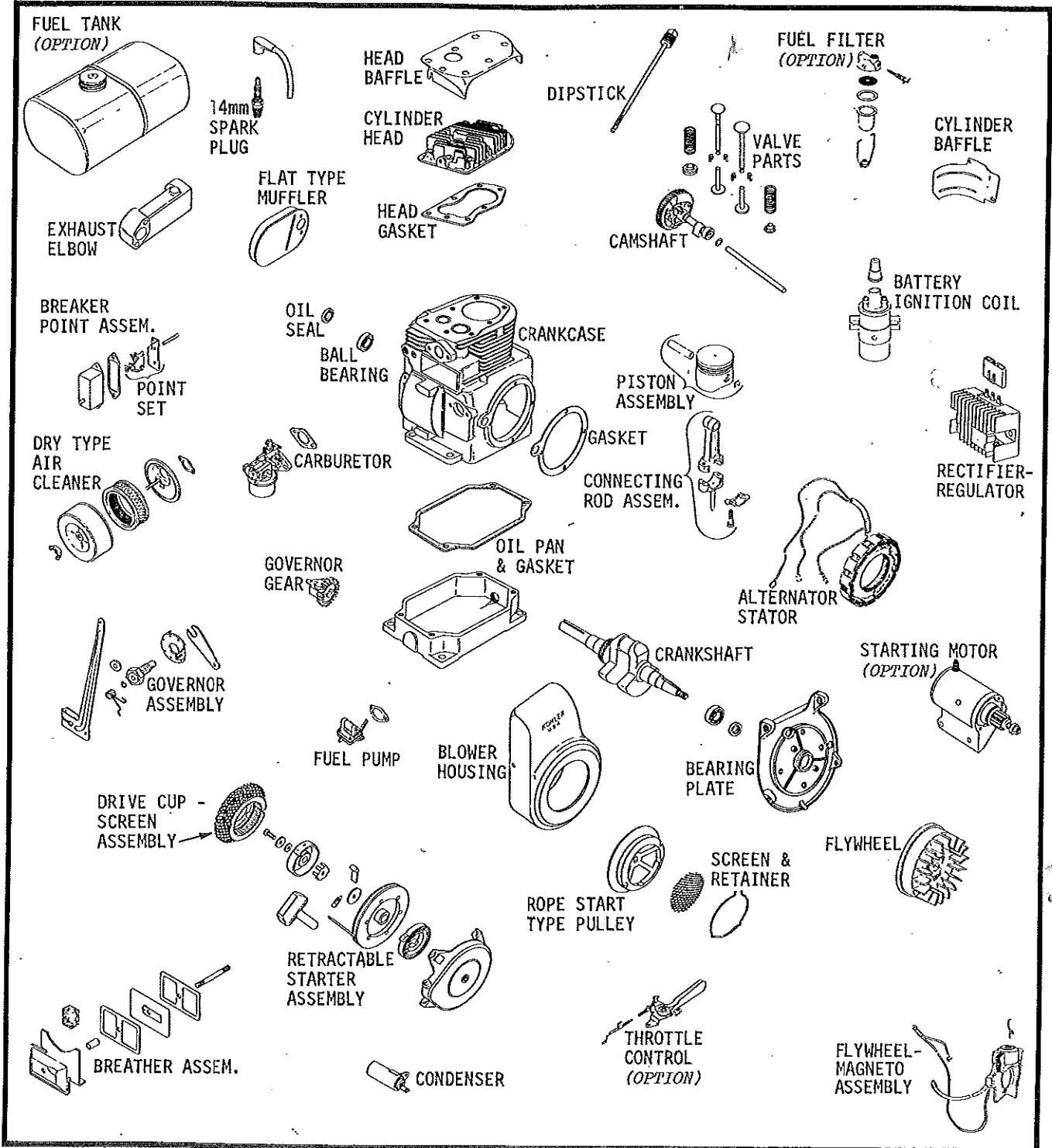

FIGURE 6 -- PARTS IDENTIFICATION - EXPLODED VIEW